



RICHMOND
THE AMERICAN INTERNATIONAL
UNIVERSITY
IN LONDON

**BA (Hons) Social Sciences: Development Studies with
Combined Studies**

Programme Specification

2015-2016

Introduction

This document describes the degree of BA (Hons) Social Sciences: Development Studies with Combined Studies awarded by Richmond University, the American International University in London, using the protocols required by the *The Framework for Higher Education Qualifications in England, Wales, and Northern Ireland* (QAA, 2014). Also key to the background for this description are the following documents:

QAA (2013). *UK Quality Code for Higher Education. Part A: Setting and maintaining academic standards and B1: Programme Design and Approval*. (www.qaa.ac.uk)

QAA (2008). *Higher Education Credit Framework for England: guidance on academic credit arrangements in Higher Education in England*.

SEEC (2010). *Credit Level Descriptors for Higher Education*. Southern England Consortium for Credit Accumulation and Transfer (www.seec.org.uk).

Middle States Commission on Higher Education. *Characteristics of Excellence in Higher Education: Requirements of Affiliation and Standards for Accreditation*. 2006, Rev. Ed. 2011. (<http://www.msche.org/publications.asp>)

The degree is delivered within the framework of a US Liberal Arts undergraduate degree programme. Typically students complete 40 separate courses over the programme which takes 3.5 to 4 years (approximately 10 courses per year, with summer courses allowing for accelerated progress in some cases). Normally, each course carries 3 US academic credits (equivalent, approximately, to 3 classroom contact hours per 15 week semester). On this basis, students are required to earn a total of 120 US academic credit hours in order to complete their degrees. Of these 40 courses, roughly half are at the “lower-division” taken in the first two years of study and coded 3000-4999, and half are at the “upper division”, taken in years three and four, and coded 5000-6999.

Richmond degrees are also articulated in terms of UK Regulatory Frameworks, chiefly the *FHEQ* and the *Higher Education Credit Framework for England*. Each course has been assigned to an appropriate level on the *FHEQ*, based on the course’s learning outcomes and assessment strategies (note that the courses comprising the first year of the 4-year US undergraduate degree are normally at QCF Level 3). US undergraduate credit can generally be translated to ECTS and UK CATS credits in the following manner: 1 US credit = 2 ECTS credits = 4 UK CATS credits. So a US degree of 120 credits would translate as 240 ECTS credits and 480 UK CATS credits (with a minimum of 360 UK CATS credits at Levels 4-6 on the *FHEQ*).

Contents

This is an interactive Table of Contents. To go directly to the Chapter, place the mouse over the chapter title, and press Ctrl and click to follow the link.

1. Overview/Factual Information	4
2. Programme aims and objectives.....	6
2.1. Educational aims and objectives of the programme.....	6
2.2. Subject benchmarks.....	6
2.3. Internal contexts	6
2.4. External contexts	7
3. Programme outcomes	8
3.1. Theoretical Knowledge Base ('A')	8
3.2. Practical Knowledge Base ('B').....	9
3.3. Cognitive Skills ('C')	10
3.4. Personal Development ('D').....	10
4. Teaching, learning and assessment strategies.....	12
4.1. Teaching and learning strategy.....	12
4.2. Assessment strategy	12
5. Programme structure	16
5.1. BA (Hons) Social Sciences: Development Studies with Combined Studies	16
5.2. Exit Award Requirements	18
5.2.1. Associate of Arts Degree in General Studies (US)	18
5.2.2. Certificate of Higher Education (UK).....	18
5.2.3. Diploma of Higher Education (UK).....	19
5.3. Minor requirements.....	20
6. Distinctive Features and Regulatory framework.....	21
6.1 Admissions	21
6.2 Assessment	22
6.3 Progression.....	22
6.4 Placement	23
6.5 Study abroad	23
6.6 Student support and guidance.....	24
Appendix I - Curriculum map.....	25
Appendix II – Programme Structure.....	28

1. Overview/Factual Information

Programme/award title(s)	BA (Hons) Social Sciences: Development Studies with Combined Studies
Teaching Institution	Richmond, the American International University in London
Awarding Institution	The Open University
Date of latest OU validation	September 2013
Next revalidation	2016-2017
Credit points for the award	120 US Credits 480 UK Credits at <i>FHEQ</i> Levels 3-6 (120 at Level 3; 120 at Level 4; 120 at Level 5; 120 at Level 6)
UCAS Code	University Code: R20 Course Code: L800
Programme start date	September 2012
Underpinning QAA subject benchmark(s)	No specific Development Studies subject benchmark. Reference has been made to: Politics and International Relations 2015 Economics 2007 Area Studies 2008 See section 2.2 below
Other external and internal reference points used to inform programme outcomes	See sections 2.3 and 2.4 below.
Professional/statutory recognition	N/A
Language of Study	English
Duration of the programme for each mode of study (P/T, FT,DL)	FT – 4 years (including one year at <i>QCF</i> Level 3)
Dual accreditation (if applicable)	Middle States Commission on Higher Education (First accredited 1981; renewed 1996 and 2006. Institutional Review scheduled for 2016.) QAA – IRENI May 2013
Date of production/revision of this specification	April 2015 (see chart below for list of revisions)

Please note: This specification provides a concise summary of the main features of the programme and the learning outcomes that a typical student might reasonably be expected to achieve and demonstrate if s/he takes full advantage of the learning opportunities that are provided.

More detailed information on the learning outcomes, content, and teaching, learning and assessment methods of each course can be found in course specification documents, syllabi, and the student handbook.

The accuracy of the information contained in this document is reviewed by the University and may be verified by the Quality Assurance Agency for Higher Education.

Programme Specification Publication Dates

First Edition	June 2012
Revision 1	August 2013
Revision 2	May 2014
Revision 3	April 2015

2. Programme aims and objectives

2.1. Educational aims and objectives of the programme

MISSION

The BA (Hons) Social Sciences: Development Studies with Combined Studies major aims to graduate students who are exceptionally strong in three core areas of Development Studies: theories and concepts of development; historical and contemporary practices of development; and contemporary issues and problems in development studies. The programme places particular emphasis on the political economy of development. A range of optional courses in national, regional and global studies, as well as in thematic areas of the discipline and where appropriate cognate fields, are offered, allowing specialisation within the Major according to student interest. Development Studies is an interdisciplinary social science, and is structured and taught accordingly, using a range of methods which reflect the international student body, whilst making the best use of emerging technologies. The courses ensure that students in other Majors can gain a sufficient understanding of Development Studies to help conceptualise the significance of the developing world in their chosen fields. The programme provides a background both for further study and eventual careers, including work in development, government, charities, international organisations, business, finance and the media.

GOALS

- To develop a broad understanding of the discipline of Development Studies.
- To competently integrate the knowledge and skills acquired in the course of studying for the UK BA (Hons) Social Sciences: Development Studies with Combined Studies within a US Liberal arts framework.
- To equip students with the skills necessary to undertake successful postgraduate study and/or applied professional training after graduation.
- To maintain academic standards equal to or better than comparable BA degrees offered by UK universities.

2.2. Subject benchmarks

No subject benchmarks are available for Development Studies, but reference is made to: Politics and International Relations 2015

(<http://www.qaa.ac.uk/en/Publications/Documents/SBS-politics-15.pdf>)

Economics 2007 (<http://www.qaa.ac.uk/en/Publications/Documents/Subject-benchmark-statement-Economics.pdf>)

Area Studies 2008 (<http://www.qaa.ac.uk/en/Publications/Documents/Subject-benchmark-statement-Area-studies.pdf>)

2.3. Internal contexts

BA (Hons) Social Sciences: Development Studies with Combined Studies features:

Detailed published educational objectives that are consistent with the mission of the institution: All course outlines contain course specific objectives that are regularly monitored by the individual instructors and by the Social Sciences faculty as a group.

Processes based on the needs of the programme's various constituencies in which the objectives are determined and periodically evaluated: Each degree's Annual Programme Evaluation (APE) is a central element of Richmond's internal quality assurance and enhancement processes. APEs measure the academic quality and standards of the programme, identify good practice, record any issues to be addressed, and, from year to year, track the ways in which those issues have been addressed. During the APE process, the academic schools:

- consider student input via course evaluations;
- consider any formalized faculty course evaluations conducted;
- consider all External Examiner reports;
- examine the Programme Specification, and note any changes required;
 - any major changes ("those which change the basic nature of the programme or student experience") to existing programmes are first approved by Academic Board;
 - in the case of validated programmes, they are also submitted to the Open University (Centre for Inclusion and Collaborative Partnerships) for external approval.

A curriculum development process that assures the achievement of the programme's objectives, and a system of ongoing evaluation that demonstrates achievement of these objectives and uses the results to improve the effectiveness of the programme: Ongoing evaluation is carried out for both the US (*Middle States*) and UK (*The Open University – CICP*) institutional reviews, and independently by departmental members (when updating courses) and by students (during regular faculty-student meetings). The Academic Board closely analyses the APEs of all degree programmes, and The University's response to the AMR is considered at the Schools and at Academic Board. A comprehensive additional formal and substantive review takes place every five years, which is also supplied to The OU as part of its revalidation process of Richmond's degree programmes.

2.4. External contexts

BA (Hons) Social Sciences: Development Studies with Combined Studies is provided through a system of ongoing evaluations that demonstrate achievement of the programme's objectives, and uses the results to improve the effectiveness of the programme. Ongoing evaluation is carried out for both US (the Middle States Commission on Higher Education) and UK (The Open University) reviews. Richmond is a voluntary subscriber member of the QAA, and underwent its first full Institutional Review in May 2013 (<http://www.richmond.ac.uk/content/admissions/about-richmond/american-british-accreditation.aspx>).

Students are encouraged to attend meetings, lectures at other London universities, institutions, think-tanks, agencies and organisations as is appropriate.

Staff all belong to professional organizations such as the Development Studies Association, Development Politics grouping within BISA, PSA, ISA, etc.

3. Programme outcomes

Programme-level learning outcomes are identified below. They are based on *SEEC* categories associated with specific levels of the *FHEQ*.

The Development Studies programme at Richmond the American International University in London is a four year programme where the discipline is studied along side a range of other subjects. Progression through the Development Studies programme is set out down each of the four columns of the Programme Outcome grid – with level-specific programme outcomes at QCF Level 3 and FHEQ Levels 4-6. The programme outcomes are then applied in each course on the Development Studies programme through assessed, courses-specific learning outcomes. The four broad categories of Programme Outcomes are:

- A) Theoretical Knowledge Base
- B) Practical Knowledge Base
- C) Cognitive Skills
- D) Personal Development

On successful completion of ***BA (Hons) Social Sciences: Development Studies with Combined Studies***, a student is expected to be able to demonstrate all of the Programme Outcomes.

Refer to Appendix I – Curriculum Map for details of how outcomes are deployed across the study programme. The programme is designed such that every learning outcome, at all levels of the programme, are assessed for every student.

3.1. Theoretical Knowledge Base ('A')

LEVEL 3

- i. Demonstrates an understanding of theories, methods and concepts appropriate for the study of development

LEVEL 4

- i. Demonstrates a broad understanding of approaches taken to the study of development in the field of economics
- ii. Demonstrates a broad and historical understanding of theories of economic and political development
- iii. Demonstrates a broad understanding of the main intellectual paradigms and debates in international relations

LEVEL 5

- i. Demonstrates a detailed understanding of economic concepts and approaches used in the study of transitional and developing states
- ii. Demonstrates a detailed understanding of theories of economic and political development in historical context
- iii. Demonstrates a critical engagement with major thinkers and intellectual paradigms within the subject area and relevant cognate fields

LEVEL 6

- i. Demonstrates a systematic understanding of the major thinkers and intellectual paradigms relevant to the study of development
- ii. Demonstrates the ability to develop critical responses to, and a systematic and historical understanding of, theoretical approaches taken in various approaches to the study of development
- iii. Demonstrates a systematic understanding of how political and economic processes can be conceptualised at the global level, and the relevance of these to the study of development
- iv. Demonstrates a systematic and interdisciplinary understanding of key texts and debates in the subject area, and the reflexive relationship between these and empirical studies of development

3.2. Practical Knowledge Base ('B')

LEVEL 3

- i. Demonstrates an understanding of social, political and economic processes relevant to the study of development

LEVEL 4

- i. Demonstrates a broad understanding of the economic challenges facing developing states
- ii. Demonstrates a broad insight into the historical development of global inequalities, and the practices that have exacerbated or alleviated this
- iii. Demonstrates a broad understanding of contemporary issues in international relations

LEVEL 5

- i. Demonstrates a detailed understanding of political and economic processes in transitional and developing states
- ii. Demonstrates a critical and theoretical engagement with core problems and issues of development, at the domestic, regional and global levels
- iii. Demonstrates a detailed understanding of the continuities and transformations evident in the core thematic debates in development studies and relevant cognate fields

LEVEL 6

- i. Demonstrates a systematic understanding of development policy making and the process of implementation of economic and political development strategies, at the domestic, regional and global levels
- ii. Demonstrates a systematic insight into the cultural, economic, environmental, geographical, historical, international, political and social dimensions of development, and of the significance of these for the subject area
- iii. Demonstrates a systematic understanding of a core problem or issue in the subject area, along with sophisticated application of theoretical knowledge to empirical evidence

- iv. Demonstrates a systematic understanding of major thematic debates in the subject area, with a sophisticated interdisciplinary analysis of development problems and issues

3.3. Cognitive Skills ('C')

LEVEL 3

- i. Demonstrates the ability to gather, organise and deploy ideas and information in order to communicate arguments effectively in written, oral or other forms, with an understanding of appropriate methods

LEVEL 4

- i. Demonstrates the ability to gather, organise and deploy ideas and information in order to evaluate their strengths and weaknesses, and express them effectively in written, oral or other forms
- ii. Demonstrates a broad understanding of quantitative and/or qualitative research methods
- iii. Demonstrates an ability to judge the reliability of sources, and begins to identify the strengths and weaknesses of concepts and theoretical frameworks

LEVEL 5

- i. Demonstrates the ability to formulate and synthesize arguments cogently, retrieve and generate information, and select appropriate criteria to evaluate sources, with a detailed understanding of quantitative and/or qualitative methods
- ii. Delivers work with limited supervision to a given length, format, brief and deadline, properly referencing sources and ideas and making use, as appropriate, of a problem-solving approach
- iii. Exercises a degree of independent and informed critical judgement in analysis

LEVEL 6

- i. Demonstrates the ability to gather, organise and deploy complex and abstract ideas and information in order to formulate arguments cogently, and express them effectively in written, oral or other forms
- ii. Demonstrates the ability to organise and manage supervised, self-directed projects, through which a sophisticated understanding of research methods is demonstrated
- iii. Demonstrates the ability to produce detailed analyses of competing perspectives and concepts, to make comparisons and connections and to identify the possibility of new concepts
- iv. Demonstrates the ability to provide critically appraisals of some of the widespread common sense understandings and misunderstandings of the subject area, and the debates and disagreements to which these give rise

3.4. Personal Development ('D')

LEVEL 3

- i. Demonstrates an awareness of views other than their own and adapts behaviour to meet obligations in personal and/or group outcomes and/or outputs

LEVEL 4

- i. Acts with limited autonomy under direction or supervision and engages in evaluation of own work and capabilities and outputs in key areas
- ii. Demonstrates broad skills that are relevant to the workplace, including the ability to work productively in a group or team, and to recognise factors that affect performance, including changing contexts, audiences and degrees of complexity
- iii. Demonstrates the ability to use a range of information communication technology (ICT) skills to perform tasks

LEVEL 5

- i. Demonstrates well-developed skills that will translate into the workplace, including the ability to work effectively within a group or team, to engage in self-reflection, and to adapt own actions and interpersonal communication skills to changing contexts, audiences and degrees of complexity
- ii. Delivers work with limited direction or supervision, demonstrating the capacity to consider and evaluate their own work using justifiable criteria
- iii. Demonstrates the ability to adapt to complex and non-routine performance tasks using information communication technology (ICT)

LEVEL 6

- i. Demonstrates the ability to act with minimal direction or supervision, to engage in self-reflection, use feedback to analyse own capabilities, appraise alternatives, and plan and implement actions
- ii. Demonstrates personal responsibility and professional codes of conduct, while taking responsibility for their own work, learning and development, and effectiveness in professional and interpersonal communication
- iii. Demonstrates flexible skills that translate directly into the workplace, including the ability to plan and manage for changing contexts, audiences and levels of complexity, and advanced group or team work capacities, for example listening, contributing, leading, negotiating and proactively managing conflict as is appropriate
- iv. Demonstrates the ability to flexibly locate their own normative views and cultural commitments within the practice of research, with a level of autonomy.

4. Teaching, learning and assessment strategies

4.1. Teaching and learning strategy

The teaching and learning strategy adopted within **BA (Hons) Social Sciences: Development Studies with Combined Studies** is as follows:

- Teaching is through lectures, seminars, tutorials, and workshops
- Regular use of individual and /or team based projects
- Use of audio-visual aids and a variety of multi-media sources
- Regular use of individual and/or group presentations
- Regular use of self-directed and directed reading in all courses
- Use of Library resources, historical archives, digital resources and online catalogues
- Use of occasional guest lecturers from specialist areas
- Frequent feedback on coursework and through one to one meetings with faculty and small group discussions
- Regular use of tutor and student led discussions groups via e-learning platforms such as Blackboard in many courses
- Using London as a resource

The combination of teaching and learning approaches mentioned above develops our students' knowledge, thinking skills and practical skills.

Their knowledge is acquired through

- Structured lectures and supporting materials
- Directed reading and use of internet materials
- Independent research

Their thinking skills are developed through

- Conducting research
- Making presentations and preparing other assessments
- Helping others to learn
- Project work employing a problem solving methodology

Their practical skills are gained through

- Application of theory to practice, especially during internships
- Using information technology to retrieve and manipulate data
- Negotiating with others in group projects

4.2. Assessment strategy

Courses in the **BA (Hons) Social Sciences: Development Studies with Combined Studies** usually meet either the Standard Assessment Norms or the Writing Intensive Assessment Norms.

Standard Assessment Norms			
FHEQ level	Richmond/UK Level	Normal number of items (including final exam)*	Total assessment
Level 3	R3000/UK A-Level	3-4	1 two-hour final exam plus 2000-2500 words
Level 4	R4000/UK Year 1	3-4	1 two-hour final exam plus 2000-3000 words
Level 5	R5000/UK Year 2	2-3	1 two-hour final exam plus 3000-4000 words
Level 6	R6000/UK Year 3	2-3	1 two-hour final exam plus 3000-4000 words
Level 7	R7000/UK MA	2-3	5000-7000 words

*** Reasonable adjustments should be made for assessment activities such as midterm tests, in- class presentations, group assignments, etc. Any summative assessment activities must be reflected in the final overall assessment count.**

Excluding all atypical courses, the following should apply to all courses:

- All undergraduate courses should include one 2-hour final exam, with exceptions approved by the department.
- Final exams should normally be no less than 25% and no more than 50% of the overall final grade.
- Instructors may not fail a student solely for failing the final exam if all graded activities result in a passing grade for the course.
- Midterm tests are optional
- At Level 3, the normal length per item should be between 500-1000 words, or equivalent (not including finals).
- At Level 4, the normal length per item should be between 1000-1500 words, or equivalent (not including finals).
- At Level 7, word count will need to take into account the inclusion of a final exam.
- Attendance and participation cannot be assessment activities.
- Formative assessments are at the discretion of the instructor and do not count toward the number of items or toward the total word count.

Writing Intensive Assessment Norms			
FHEQ level	Richmond/UK Level	Normal number of items	Total assessment
Level 3	R3000/UK A-Level	3-4	3000-3250 words
Level 4	R4000/UK Year 1	3-4	3000-4500 words
Level 5	R5000/UK Year 2	2-3	4500-6000 words
Level 6	R6000/UK Year 3	2-3	4500-6000 words

Courses designated as Writing Intensive differ from the Standard Assessment Norms by:

- No final exam
- The total amount of written words will normally increase by 50%

There are some other exceptions and those courses will follow a Special Programmes (e.g. ADM, ARW) or Dissertation table approved on 28 June 2012 by Academic Council. Details of these can be found at <http://www.richmond.ac.uk/admitted-students/>

For courses that have atypical assessment norms and do not follow one of the approved tables, assessment will first be approved by Learning and Teaching Policy Committee.

Grade Assessment Criteria/Marking Scheme

Assessment in the **BA (Hons) Social Sciences: Development Studies with Combined Studies** is by examination; book reviews, essays, dissertations, and other forms of written work; oral presentations and participation in group and sub-group work; and individual and group projects.

In order to obtain a **BA (Hons) Social Sciences: Development Studies with Combined Studies** students require (amongst other requirements) a cumulative GPA across the entire degree of 2.0. This is a 'C' average. A minimum GPA of 2.0 must also be achieved in all courses taken to fulfil major requirements. For information on the calculation of the UK GPA as a basis for final degree classifications, see the myacademics page of the university portal at: <https://my.richmond.ac.uk/myacademics/default.aspx>

Course syllabi documents clarify, for each learning outcome, how that particular learning outcome is assessed, and what the threshold criteria for that particular learning outcome is, specified at the 'C' (GPA 2.0) level (i.e. a passing grade)

There are three 'pass' grades (and 7 sub-categories of 'pass' grade) in the **BA (Hons) Social Sciences: Development Studies with Combined Studies**. The following general criteria are used to distinguish between these grades:

Grade A applies only to the exceptional piece of work which:

- has continued beyond the B grade band to develop a more advanced analytical and integrative command of the material and issues
- gives evidence of very wide reading and extensive knowledge of relevant theory and recent research
- is very well structured, putting forward cogent arguments which are well supported by carefully evaluated evidence
- superior (A-) or outstanding (A)

Grade B applies to work which:

- goes beyond the foundation level to develop a more questioning & analytical approach
- goes beyond the basic required reading, to study/discuss recommended texts & articles
- indicates an increasing ability to appreciate an extensive body of knowledge and to conceptualize the key theories, issues, debates and criticisms
- demonstrates the skills to present a balanced and comprehensive discussion
- has been completed with a thoroughness aimed to get the most learning out of the exercise
- good quality (B-), very good (B), or excellent (B+)

Grade C applies to work which:

- is basically competent, although undeveloped
- fulfils the requirements of the assignment at a foundation level, involving:
 - adequate coverage of the essential information specified, and
 - the skill to present that material coherently
- selects relevant named references and quotations
- just below average (C-), average (C), or showing signs of reaching above average (C+)

Grade D applies to work which:

- has been done without proper understanding of the requirements
- is too short, or long and unedited or lacks structure
- relies on superficial, subjective statements
- uses unreliable and inappropriate sources, **such as Wikipedia**
- uses incorrect, or confused information
- fails to make proper use of named references and quotations
- unsatisfactory work (D-), very poor work (D) and work which is weak (D+)

Grade F, a fail, applies to:

- non-submission of work or work which is illegible
- late work after one extension has been given
- work which may be competent, but is either:
 - irrelevant (i.e. does not address the requirements of the assignment), or
 - uses un-attributed material (plagiarism)

5. Programme structure

5.1. BA (Hons) Social Sciences: Development Studies with Combined Studies

A normal course load per academic year is 30 US credits, equivalent to 120 UK credits. Students complete 120 UK credits at Level 6 in the major.

Please see degree chart below and refer to **Appendix 2: Programme Structure Flowchart**.

Please note that students must complete all General Education requirements AND a minimum of 120 credits at each FHEQ level. The Gen Ed programme commencing Fall 2015 offers more choice amongst levels, so students and advisors must ensure that both Gen Ed requirements and overall level requirements are satisfied. As long as a minimum 120 credits per level is achieved, Gen Ed Options I and II will be automatically fulfilled.

Table 1: Lower-Division / Levels 3 and 4 Degree Requirements

LOWER-DIVISION REQUIREMENTS			
QCF Level 3		US CREDITS	UK CREDITS
DEV 3100	Development & Culture: Representations in Film & Lit	3	12
ECN 3100	Foundations of Economics	3	12
MTH 3111	Functions and Applications	3	12
SCL 3100	Foundations of Sociology	3	12
	15 US/60 UK credits (5 further courses): General Education requirements¹	15	60
	3 US/12 UK credits (typically 1 further course)²	3	12
QCF Level 3 CREDIT TOTALS		30	120

FHEQ Level 4		US CREDITS	UK CREDITS
DEV 4100	Rich World/Poor World	3	12
ECN 4100	Introduction to Economics of Development	3	12
ECN 4105	Introduction to Microeconomics	3	12
ECN 4110	Introduction to Macroeconomics	3	12
INR 4100	Introduction to International Relations	3	12
MTH 4120	Probability and Statistics I	3	12
	3 US/12 UK credits (1 further course): General Education requirement³	3	12
	9 US/36 UK credits (typically 3 further courses)⁴	9	36
FHEQ Level 4 CREDIT TOTALS		30	120

¹ Level 3 Gen Ed requirements: GEP 3100 Transitions I; GEP 3101 Transitions II; GEP 3140 Scientific Reasoning; GEP 3160 Creative Expression; GEP 3180 Research and Writing I.

² 3 US/12 UK credits to be completed at Level 3 consists of one of the following: MTH 3000 (if the student needs to complete it); Gen Ed Humanities/Social Sciences Option (if taken at Level 3); Gen Ed Option I and/or II (if taken at Level 3); Free elective/Minor Requirement. For details of the Gen Ed options, please see the [Gen Ed Programme Specification](#).

³ Level 4 Gen Ed requirement: GEP 4180 Research and Writing II.

⁴ 9 US/36 UK credits to be completed at Level 4 consist of some elements of the following in combination: Gen Ed Humanities/Social Sciences Option (if taken at Level 4); Gen Ed Option I and/or II (if taken at Level 4); Free elective(s)/Minor Requirements. For details of the Gen Ed options, please see the [Gen Ed Programme Specification](#).

Table 2: Upper-Division / Levels 5 and 6 Requirements

UPPER-DIVISION REQUIREMENTS			
FHEQ Level 5		US CREDITS	UK CREDITS
DEV 5100	Global Development Politics	3	12
ECN 5100	Economics of Transition	3	12
ECN 5105	Economic Problems of Developing Countries	3	12
SCL 5200	Social Research	3	12
plus 2 of the following:		6	24
AMS 5200	Power in the Americas		
HST 5100	Cultures Of Imperial Power		
HST 5110	Nationalism And Conflict		
HST 5430	War of the Worlds? Empire and Civilization		
INR 5100	Critical Globalization Studies		
INR 5200	Global Governance		
INR 5205	Security Studies		
INR 5405	Miracle To Meltdown: East & Southeast Asia		
LIT 5420	Postcolonial Literatures		
PLT 5100	Politics Of The Middle East		
PLT 5200	Political Economy: Capitalism and its Critics		
PLT 5410	Islam and The West		
PLT 5415	Politics Of Sub-Saharan Africa		
PLT 5420	Russian Politics and History		
PLT 5425	Modern China		
12 US/48 UK credits (typically 4 further courses)⁵		12	48
FHEQ Level 5 Credit Totals		30	120

FHEQ Level 6		US CREDITS	UK CREDITS
DEV 6200	Sustainable Development	3	12
DEV 6205	Postcolonial Theory and Development	3	12
DEV 6296	Senior Seminar in Development Studies 1	3	12
DEV 6297	Senior Seminar in Development Studies 2	3	12
INB 6200	Country Risk Analysis	3	12
INR 6205	International Political Economy	3	12
plus 4 of the following OR Internship and 2 of the following:		12	48
AVC 6400	Non-Western Visual Cultures		
DEV 6962	World Internship in Development Studies (6 CREDITS)		
DEV 6972	Internship in Development Studies (6 CREDITS)		
HST 6410	Migration and Diasporas		

⁵ 12 US/48 UK credits to be completed at Level 5 consist of some elements of the following in combination: Gen Ed Option I and/or II (if taken at Level 5); Free elective(s)/Minor Requirements. For details of the Gen Ed options, please see the [Gen Ed Programme Specification](#).

INR 6210	The Politics of International Law		
INR 6400	Conflict And Peace Studies		
INR 6405	International Human Rights		
INR 6415	Foreign Policy Analysis		
INR 6420	Global Energy Politics		
PLT 6205	Policy-Making in a Globalized World		
PLT 6415	Ethnicity and Identity		
PLT 6420	Gender, Politics and International Relations		
PLT 6425	Religion, Identity And Power		
PLT 6430	Democracy and Democratization		
FHEQ Level 6 Credit Totals		30	120

5.2. Exit Award Requirements

An exit award is defined as a lower award than one for which the student is registered. Such an award may be conferred if a student completes part, but not all, of the requirements of the programme for which he or she is registered. Students may not enter the university registered for an exit award.

5.2.1. Associate of Arts Degree in General Studies (US)

The US Associate of Arts (AA) degree can be awarded as an exit degree for those students completing the following minimum requirements.

30 US / 120 UK credits at QCF Level 3

30 US / 120 UK credits at FHEQ Level 4

Of the total number of credits required for the AA degree, 30 US/120 UK credits must be completed at Richmond. Students must obtain a minimum cumulative GPA of 2.0 and a major of 2.0 in order to qualify for this degree. Latin Honours are not applied to the AA Degree.

The requirements for the AA degree are outlined in Table 1 above.

5.2.2. Certificate of Higher Education (UK)

The UK Certificate of Higher Education (CertHE) can be broadly aligned with the US Associate of Arts Degree, but the CertHE does not require the completion of 30 US/120 credits at QCF Level 3. Students who qualify for the AA degree will automatically qualify for the CertHE. But students may qualify for a CertHE without fulfilling the requirements for a US AA degree if they have not completed all of the QCF Level 3 requirements necessary to obtain the AA.

Students may not be awarded more than one exit award (notwithstanding dual accreditation of the AA/CertHE) and Boards will recommend the most relevant one for the individual student circumstance for any student meeting the criteria for an award to be made.

The UK CertHE can be awarded as an exit award for those students completing the following minimum requirements.

120 credits at FHEQ Level 4

- Pass (normally a GPA of between 1.85 and 2.99 for all Level 4 courses, corresponding with a UK average of between 40% and 59%)*
- Merit (normally a GPA of 3.0 to 3.54, corresponding with a UK average of between 60% and 69%)*
- Distinction (normally a GPA of 3.55 and above for all level 4 courses, corresponding with a UK average of 70% and over)*

*See Richmond OU/US Grading Translation Scale in *2015-2016 Catalogue*. Note that the Grading Translation will be phased in over several years starting with Level 3 courses in 2015-2016.

Of the total number of credits required for the UK CertHE, 15 US/60 UK credits must be completed at Richmond.

The requirements for the UK CertHE are outlined in the section of Table 1 pertaining to FHEQ Level 4 requirements.

5.2.3. Diploma of Higher Education (UK)

The UK Diploma of Higher Education (DipHE) has no US equivalent. The UK DipHE can be awarded as an exit award for those students completing the following minimum requirements.

120 credits at FHEQ Level 4

120 credits at FHEQ Level 5

- Pass (normally a GPA of between 1.85 and 2.99 for all Level 4 courses, corresponding with a UK average of between 40% and 59%)*
- Merit (normally a GPA of 3.0 to 3.54, corresponding with a UK average of between 60% and 69%)*
- Distinction (normally a GPA of 3.55 and above for all level 4 courses, corresponding with a UK average of 70% and over)*

*See Richmond OU/US Grading Translation Scale in *2015-2016 Catalogue*. Note that the Grading Translation will be phased in over several years starting with Level 3 courses in 2015-2016.

Of the total number of credits required for the UK DipHE, 15 US/60 UK Level 4 credits and 15 US/60 UK Level 5 credits must be completed at Richmond.

The requirements for the UK DipHE are outlined in the sections of Table 1 and Table 2 above pertaining to FHEQ Level 4 and FHEQ Level 5 requirements.

5.3 Minor requirements

Students may select Development Studies as an optional minor to complement their major field. Both the major and minor will be recorded on the student's transcript at graduation. At least three of the upper division courses required for a minor must be taken at Richmond. A maximum of three courses only may overlap between a student's major and any minor.

		US Credits	UK Credits
Minor Requirements		18	72
DEV 3100	Development and Culture	3	12
DEV 4100	Rich World Poor World	3	12
DEV 5100	Global Development Politics	3	12
<i>Plus any THREE of the following courses:</i>		9	36
AMS 5200	Powers in the Americas		
DEV 6200	Sustainable Development		
DEV 6205	Postcolonial Development and Theory		
ECN 5100	Economics of Transition		
ECN 5105	Economic Problems of Developing Countries		
INR 5405	Miracle To Meltdown: E&SE Asia		
PLT 5100	Politics of the Middle East		
PLT 5410	Islam and the West		
PLT 5415	Politics of sub-Saharan Africa		
PLT 5420	Russian Politics and History		
PLT 5425	Modern China		

6. Distinctive Features and Regulatory framework

BA (Hons) Social Sciences: Development Studies with Combined Studies is distinctive in that it broadens the academic experience of the students as a consequence of Richmond's US Liberal Arts framework and General Education requirements, and deepens it through the sequence of course requirements within the programme. This balance between a core of requirements and a range of choices is a key characteristic of the US system of Liberal Arts undergraduate education. While mapping of the US system onto UK regulatory frameworks has presented another opportunity for quality enhancement, accommodation of the special nature of the US liberal arts degree is achieved in the additional "Combined Studies" designation for each major. Developing this distinctive approach, the Richmond programme aspires to the best theory and practice from both sides of the Atlantic.

The **BA (Hons): Social Sciences: Development Studies with Combined Studies** is operated under the policy and regulatory frameworks of Richmond the American International University in London, the Middle States Commission on Higher Education, the *Framework of Higher Education Qualifications*, *UK Quality Code for Higher Education*, and The Open University policies and procedures for validated institutions..

The following sub-sections include the relevant University or institutional policy documents, where applicable.

6.1 Admissions

To be considered for admission, prospective students should:

- normally be at least 17 years old, have completed a minimum of 12 years of schooling, and hold the required grade(s) in a complete US high School Diploma, UK GCE A levels, or other UK or international qualifications deemed equivalent by the University, by the start of the programme;
- have completed an application via UCAS, the Common Application or direct to the University, including a personal statement and academic reference and supplying verification of existing academic and English language attainments as required by the University.

Further details of qualifications accepted and grades required may be found on the University website, noting that these are common to all BA programmes at the University and there is no requirement as to the subject of entry qualifications. Prospective students from the United States should note that SATs are optional but not required. Whilst not routinely required, prospective students may be invited to interview where this is considered necessary in order to fully consider their application.

Prospective students with specific levels of subject achievement in Advanced Placement Tests, GCE A Levels and some other UK and international qualifications may enter with Advanced Credit and be given exemption from certain courses of the programme. Normally, Advanced Credit may be given for a maximum of 30 out of the total 120 (US)

credits necessary to complete the programme. The University also welcomes applications from prospective students with previous Higher Education study who, depending on subjects taken and grades achieved, may be given up to 75 Transfer Credits against the total 120 (US) credits necessary to complete the programme.

Students who are not nationals of a majority English-speaking country should normally have achieved CEFR level B2 in a secure English Language test acceptable to the University prior to entry to the programme. At the University's discretion, students in this category who are EEA nationals may be excused this requirement where they have recently undertaken a full time programme of study of at least 2 years duration with English as the medium of instruction.

Prospective students who do not meet the above academic and/or English language requirements may be permitted to enter this programme at the appropriate point after having first satisfactorily completed a Foundation Year and /or Academic English language programme at the University.

Further details of all of the above may be found at the appropriate page of the University website, where a comprehensive Admissions Policy and Summary of Practice document is also published (<http://www.richmond.ac.uk/content/admissions.aspx>)

6.2 Assessment

A proper assessment of student learning and progression of skills gained is fundamental to the work of the University. Much of what shapes the University's perspective on this has already been mentioned within section 4.2, above, under Assessment Strategy, which has been shaped in accordance with the expectations outlined in Section B6 of the *UK Quality Code for Higher Education*.

The University is also in compliance with Standard 14 on 'Assessment of Student Learning', as laid out by the Middle States Commission on Higher Education. Standard 14 includes the following passages:

"The systematic assessment of student learning is essential to monitoring quality and providing the information that leads to improvement. Implemented effectively, the assessment of student learning will involve the shared commitments of students, administrators and academic professionals... Assessment is not an event but a process and should be an integral part of the life of the institution."

(<http://www.msche.org/publications.asp>).

6.3 Progression

Progression is built into the Programme Outcomes (Section 3 above), as they are derived from the *SEEC* categories associated with specific levels of the *FHEQ*. Learning outcomes in each individual course are therefore level-specific, ensuring an appropriate structure of progression through the degree, with students at graduation meeting the requirements of the QAA subject benchmarks.

6.4 Placement

The Internship Office the University offers a formal mechanism through which students may receive work-placement opportunities. These placements are supervised, career-related work experiences combined with reflective, academic study that help students apply theoretical knowledge in the workplace. Participation in the internship programme is optional, but students who choose to take up a placement receive academic credit for their placement and associated academic work. For full details of the internship programme, please see: <http://www.richmond.ac.uk/content/academic-programs/internships.aspx>

Expectations with regard to careers education, information, advice and guidance (as outlined in Section B4 of *The UK Quality Cole for Higher Education*) are handled by the university's Student Affairs department. This department conducts a variety of career services for students, ranging from resource provision to a CV service, and in particular through the LEAD (Leadership, Education and Development) seminar series. For full details of career services offered to students at Richmond, please see: <http://www.richmond.ac.uk/content/student-affairs/career-services.aspx>.

In addition to these services, the alumni office offers networking opportunities where students may contact alumni working in a variety of fields. The alumni office also offers these services via social media such as LinkedIn and Facebook. Please see: <http://www.richmond.ac.uk/content/alumni.aspx>

6.5 Study abroad

Richmond classes benefit every semester through the arrival of study abroad students from colleges and universities within the United States. These students, who mostly enrol in classes at levels 5 and 6, very often bring with them a distinct set of values and approaches to learning that can be both enriching and challenging. Richmond faculty have the breadth of experience necessary with which to capitalise on the positive aspects of this class room dynamic. Please note that Study Abroad students register for classes *after* Richmond degree-course students have completed their registration process.

Richmond students have the option to take a leave of absence and travel away from the university as a 'study abroad'. In practice, however, very few students take this option up. It is more common for Richmond students to take a limited number of classes at other accredited colleges and universities during the summer, and then transfer these back to Richmond for inclusion toward their graduation requirements. All courses taken elsewhere must be pre-approved by the Office of Academic Affairs. All such courses are rigorously scrutinized, and only credit from appropriately accredited programmes, earned with a grade of C or above, are accepted for transfer. There are strict requirements regarding the number of courses and at what level may be taken outside of Richmond. Please see under "Graduation Requirements" at:

<http://www.richmond.ac.uk/content/academic-affairs/graduation/graduation-requirements.aspx>

6.6 Student support and guidance

All students have an allocated full-time faculty member who acts as their academic adviser. Academic Advisers have on-going responsibility for students' academic progress, meeting with each advisee at least once per semester. Advisers assist students with course selection and registration, enabling smooth progression through the degree. They also advise on postgraduate and career opportunities, and also provide pastoral support in many cases.

Students admitted from Fall 2013 onwards have an on-line "Academic Plan" made available to them, which acts as an interactive degree planner, outlining degree requirements, and recording their completion – this enables students to track their progress towards their degree.

A range of Maths, English, Technology and Writing workshops have been established to support students with particular needs in these areas. Librarians are on hand to assist with library use, which includes instruction in web-based resources.

In accordance with the 2010 *Equality Act*, and with Chapter B4 of the *Quality Code*, Richmond endeavours to make all practical and reasonable adjustments to ensure students are able to fully participate in the University community. Students who declare a physical disability or a special educational need are accommodated to ensure the quality of their educational experience meets their individual requirements – the university disability officer works with individual students to determine accommodations, and works with colleagues in the Academic Registry and the Schools to see that their needs are addressed. SEN students, for instance, receive extra time in examinations, and have the option of writing exams on university-provided computers, and/or of taking exams in a separate room. Please see:

<http://www.richmond.ac.uk/content/student-affairs/students-with-disabilities.aspx>

The University operates a well-staffed Student Affairs department headed by the Vice-President for Students that provides services intended to support and encourage student welfare, safety and development. This department oversees medical registration of students and provides counseling services. It also organizes a range of extracurricular activities and travel designed to further enhance students' educational experiences. The university [Student Charter](#) outlines responsibilities and expectations of both the students and the university, and the [Conduct Code](#) addresses expectations as to social conduct. Non-academic appeals and complaints and disciplinary incidents are overseen by the Student Affairs Department.

In its 2013 [IRENI review](#), Richmond was commended for "The care and attention paid to academic and pastoral support for international students throughout their association with the University.

Appendix I - Curriculum map

Green Cells are core course from within the Development Studies Programme

Pink Cells are core courses from other Programmes. Their learning outcomes are derived from their relevant programme specifications. They have been fitted as well as possible into the Development Studies Curriculum Map

Yellow Cells would delineate optional courses from within the Development Studies Programme if offered in future

LEVEL 3	DEV 3100 Development & Culture	ECN 3100 Foundations of Economics	SCL 3100 Foundations of Sociology	MTH 3111 Functions & Applications
A3(i)	X	X	X	
B3(i)	X	X	X	
C3(i)	X	X	X	X
D3(i)	X	X	X	X

LEVEL 4	DEV 4100 Rich World /Poor World		ECN 4105 Intro to Micro	ECN 4110 Intro to Macro	ECN 4100 Intro to Econ of Developm	INR 4100 Intro to IR	MTH4120 Probability & Stats I
A4(i)					X		
A4(ii)	X						
A4(iii)						X	
B4(i)	X				X		
B4(ii)	X						
B4(iii)						X	
C4(i)	X					X	
C4(ii)			X	X	X		X
C4(iii)	X					X	
D4(i)	X					X	
D4(ii)	X						
D4(iii)	X					X	X

LEVEL 5	DEV 5100 Global Dev Politics		ECN 5100 Economics of Transition	ECN 5105 Econ Probs Developing Countries	SCL 5200 Social Research
A5(i)			X	X	
A5(ii)	X				
A5(iii)	X				
B5(i)			X	X	
B5(ii)	X		X	X	
B5(iii)	X				
C5(i)	X		X	X	X
C5(ii)	X				X
C5(iii)	X				X
D5(i)	X				X
D5(ii)					X
D5(iii)	X				X

LEVEL 6	DEV 6200 Sustainable Development	DEV 6205 Postcolonial Theory & Dev	DEV 6296 Senior Seminar I	DEV 6297 Senior Seminar II		INR6205 International Political Econ	INB6200 Country Risk Analysis
A6(i)	X	X				X	
A6(ii)	X	X				X	
A6(iii)						X	
A6(iv)	X		X	X		X	
B6(i)	X					X	
B6(ii)	X					X	
B6(iii)			X	X			
B6(iv)	X		X	X		X	
C6(i)	X	X	X	X		X	
C6(ii)			X	X			

C6(iii)	X	X	X	X		X	
C6(iv)	X	X	X	X		X	
D6(i)			X	X			
D6(ii)	X	X	X	X		X	
D6(iii)	X			X			X
D6(iv)	X	X	X	X		X	

For the following courses see relevant programme specifications: PLT5100, PLT5200, PLT5410, PLT5415, PLT5420, PLT5425, PLT6205, PLT6415, PLT6420, PLT6425, PLT6430, INR5100, INR5200, INR5205, INR5405, INR6210, INR6400, INR6405, INR6415, INR6420, HST5100, HST 5110, LIT 5105, Internship

Appendix II – Programme Structure

Typical Degree Schema: *BA (Hons) Social Sciences: Development Studies with Combined Studies.*

(Note: Based on a Freshman entering Richmond with no Transfer Credit)

YEAR ONE:

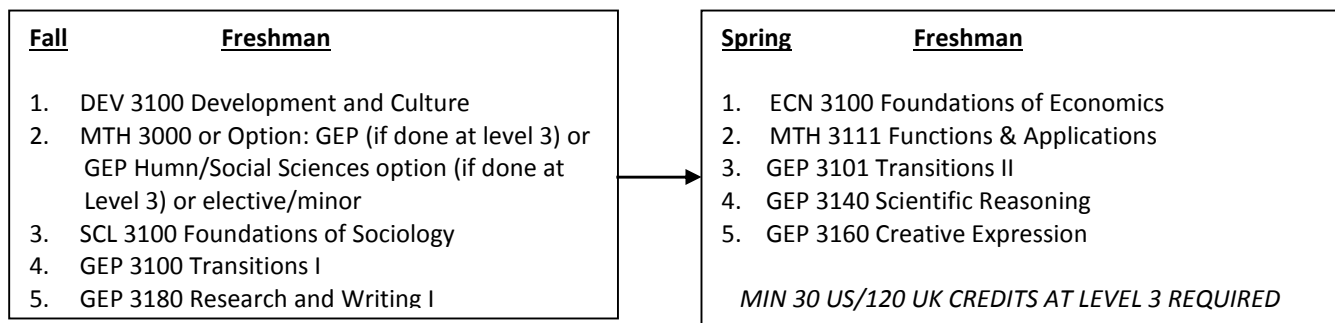

YEAR TWO:

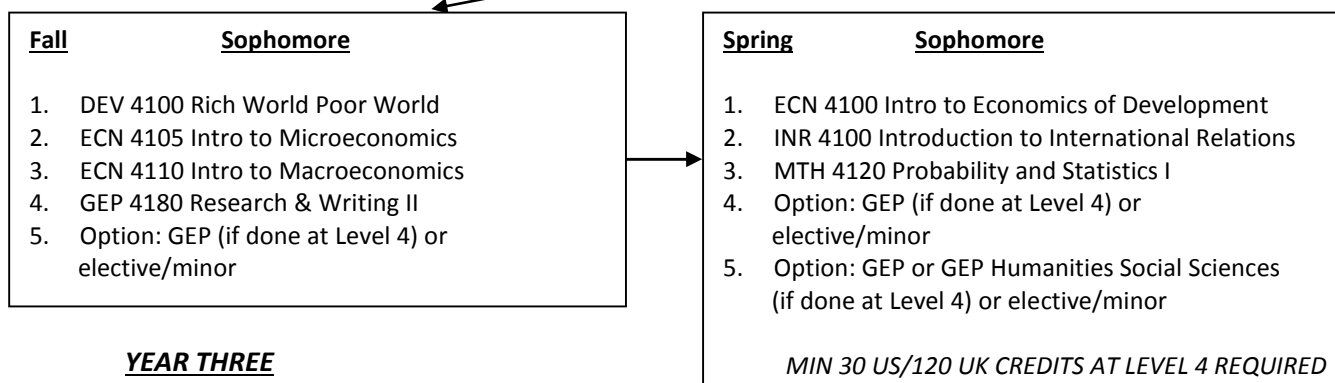

YEAR THREE

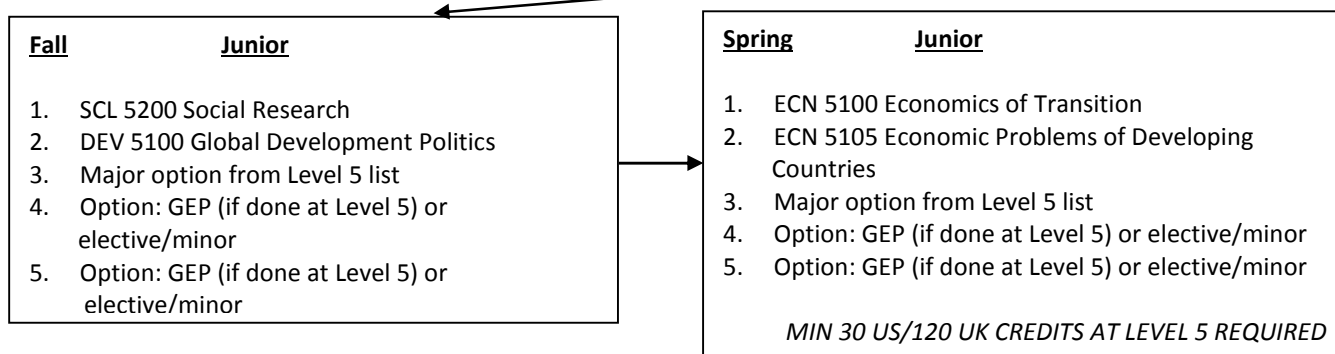

YEAR FOUR:

