



RICHMOND
THE AMERICAN INTERNATIONAL
UNIVERSITY
IN LONDON

BA (Hons) Social Sciences: Psychology with Combined Studies

Programme Specification

August 2013

Introduction

This document describes the degree of **B.A. (Hons) Social Sciences: Psychology with Combined Studies** awarded by Richmond the American International University in London using the protocols required by *The Framework for Higher Education Qualifications in England, Wales, and Northern Ireland* (QAA, 2008). Also key to the background for this description are the following documents:

QAA (2011). *UK Quality Code for Higher Education. Part A: Setting and maintaining threshold academic standards A3: The Programme Level and Part B: Assuring and Enhancing Academic Quality B1: Programme Design and Approval.* (www.qaa.ac.uk)

QAA (2008). *Higher Education Credit Framework for England: guidance on academic credit arrangements in Higher Education in England.*

SEEC (2010). *Credit Level Descriptors for Higher Education.* Southern England Consortium for Credit Accumulation and Transfer (www.seec.org.uk).

Middle States Commission on Higher Education. *Characteristics of Excellence in Higher Education: Requirements of Affiliation and Standards for Accreditation.* 2006, Rev. Ed. 2011. (<http://www.msche.org/publications.asp>)

The degree is delivered within the framework of a US Liberal Arts undergraduate degree programme. Typically students complete 40 separate courses over the programme which takes 3.5 to 4 years (approximately 10 courses per year, with summer courses allowing for accelerated progress in some cases). Normally, each course carries 3 US academic credits (equivalent, approximately, to 3 classroom contact hours per 15 week semester). On this basis, students are required to earn a total of 120 US academic credit hours in order to complete their degrees. Of these 40 courses, roughly half are at the “lower-division” taken in the first two years of study and coded 3000-4999, and half are at the “upper-division”, taken in years three and four, and coded 5000-6999.

Richmond degrees are also articulated in terms of UK Regulatory Frameworks, chiefly the *FHEQ* and the *Higher Education Credit Framework for England*. Each course has been assigned to an appropriate level on the *FHEQ*, based on the course’s learning outcomes and assessment strategies (note that the courses comprising the first year of the 4-year US undergraduate degree are normally at Level 3). US undergraduate credit can *generally* be translated to ECTS and UK CATS credits in the following manner: 1 US credit = 2 ECTS credits = 4 UK CATS credits. So a US degree of 120 credits would translate as 240 ECTS credits and 480 UK CATS credits (with a minimum of 360 UK CATS credits at Levels 4-6 on the *FHEQ*).

Contents

This is an interactive Table of Contents. To go directly to the Chapter, place the mouse over the chapter title, and press Ctrl and click to follow the link.

1. Overview/Factual Information.....	4
2. Programme aims and objectives.....	6
2.1. Educational aims and mission of the programme.....	6
2.2. Subject benchmarks	6
2.3. Internal contexts:.....	7
2.4. External contexts:.....	8
3. Programme Outcomes.....	9
3.1. Theoretical Knowledge Base ('A')	9
3.2. Practical Knowledge Base ('B')	10
3.3. Cognitive Skills ('C').....	10
3.4. Personal Development	11
4. Teaching, learning and assessment strategies	12
4.1. Teaching and learning strategies	12
4.2. Assessment strategy	13
5. Programme structure:	16
5.1. B.A. (Hons) Social Sciences: Psychology with Combined Studies	16
5.2. Minor requirements.....	17
6. Regulatory framework.....	18
6.1. Admissions	18
6.2. Assessment	19
6.3. Progression.....	19
6.4. Placement.....	19
6.5. Study abroad.....	20
6.6. Student support and guidance.....	20
Appendix 1 - Curriculum map	22
Appendix 2 - Programme structure	25

1. Overview/Factual Information

Programme/award title(s)	BA (Hons) Social Sciences: Psychology with Combined Studies
Teaching Institution	Richmond, the American International University in London
Awarding Institution	The Open University
Date of latest OU validation	September 2012
Next revalidation	2016-2017
Credit points for the award	126 US Credits 504 UK Credits (124 at <i>FHEQ</i> Level 3; 124 at level 4; 128 at level 5; 128 at level 6)
UCAS Code	University Code: R20 Course Code: C880
Programme start date	September 1997
Underpinning QAA subject benchmark(s)	QAA benchmark statement for Psychology 2007 (3 rd edition, 2010). http://www.qaa.ac.uk/Publications/InformationAndGuidance/Documents/Psychology2010.pdf
Other external and internal reference points used to inform programme outcomes	See sections 2.3 and 2.4 below.
Professional/statutory recognition	N/A
Language of Study	English
Duration of the programme for each mode of study (P/T, FT,DL)	FT – 4 years (including one year at <i>FHEQ</i> Level 3)
Dual accreditation (if applicable)	Middle States Commission on Higher Education (First accredited 1981; renewed 1996 and 2006. Institutional Review scheduled for 2016.) QAA – IRENI May 2013
Date of production/revision of this specification	June 2013 (see chart below for list of revisions)

Please note: This specification provides a concise summary of the main features of the programme and the learning outcomes that a typical student might reasonably be expected to achieve and demonstrate if s/he takes full advantage of the learning opportunities that are provided.

More detailed information on the learning outcomes, content, and teaching, learning and assessment methods of each module can be found in course specification documents, syllabi, and the student handbook.

The accuracy of the information contained in this document is reviewed by the University and may be verified by the Quality Assurance Agency for Higher Education.

Programme Specification Publication Dates

First Edition	20 June 2006
Revision 1	February 2008
Revision 2	June 2009
Revision 3	May 2010
Revision 4	February 2012
Revision 5	June 2012 (substantive revision, including <i>FHEQ</i> and credit mapping)
Revision 6	August 2013

2. Programme aims and objectives

2.1. Educational aims and mission of the programme

MISSION

Richmond's Psychology programme promotes the acquisition and demonstration of conceptual knowledge in the core areas of the Psychology discipline such as development, language, phenomenology, personality theory and individual differences, biological psychology, social psychology, psychopathology, cognitive science, and research methods. Psychology students are expected to progressively integrate theoretical perspectives and empirical findings, use appropriately a variety of research approaches and apply psychological principles in a variety of professional settings such as clinical, counselling, educational and legal.

GOALS

- To develop a broad understanding of the theory and practice in Psychology.
- To competently integrate the knowledge and skills acquired in the course of studying for the UK BA (Hons) Social Sciences: Psychology with Combined Studies within a U.S. Liberal Arts framework.
- To equip students with the skills necessary to undertake successful postgraduate study and/or applied professional training after graduation.
- To maintain academic standards equal to or better than comparable BA degrees offered by U.K. universities.

Upon completion of the BA (Hons) Social Sciences: Psychology with Combined Studies degree, students should be able to:

- demonstrate their knowledge of functions of the mind, functions of the brain and personal and group experience, and their interaction
- command a variety of theoretical and research perspectives and evaluate their contributions and limitations
- understand the historical context and progress in psychological theory and research, and current trends and debates in research, theory development and clinical applications
- appreciate the impact of psychology in a cross-cultural and societal context
- recognize the interaction of psychology with other disciplines such as philosophy, medicine, neuroscience, biochemistry, business and education
- conduct both qualitative and quantitative research projects; and adhere to the ethical principles guiding research and professional conduct
- demonstrate critical thinking skills, writing and presentation skills

2.2. Subject benchmarks

QAA benchmark statement for Psychology 2007 (3rd edition, 2010).

<http://www.qaa.ac.uk/Publications/InformationAndGuidance/Documents/Psychology2010.pdf>

The benchmark statement for Psychology places great emphasis on the successful delivery of Research Methodology courses and a multiple-perspective approach to course content development and focus of teaching methodology. Additionally, threshold and typical standards are suggested for Psychology students to achieve upon completion of the degree. The program outcomes conform to the benchmark statement.

All Psychology syllabi conform to the requirement for threshold standards to be communicated to the students and are clearly linked to assessment in each course. These reflect the Psychology mission statement, the goals of the programme and the content of each course.

2.3. Internal contexts:

BA (Hons) Social Sciences: Psychology with Combined Studies features:

(a) Detailed published educational objectives that are consistent with the mission of the institution: All course outlines contain course specific objectives that are regularly monitored by the individual instructors and by the Humanities and Social Sciences faculty as a group.

(b) Processes based on the needs of the programme's various constituencies in which the objectives are determined and periodically evaluated: Each degree's Annual Programme Evaluation (APE) is a central element of Richmond's internal quality assurance and enhancement processes. APEs measure the academic quality and standards of the programme, identify good practice, record any issues to be addressed, and, from year to year, track the ways in which those issues have been addressed. During the APE process, the academic schools:

- consider student input via course evaluations;
- consider any formalized faculty course evaluations conducted;
- consider all External Examiner reports;
- examine the Programme Specification, and note any changes required;
 - any major changes ("those which change the basic nature of the programme or student experience") to existing programmes are first approved by LTPC;
 - in the case of validated programmes, they are also submitted to the Open University (Centre for Inclusion and Collaborative Partnerships) for external approval.

(c) A curriculum development process that assures the achievement of the programme's objectives, and a system of ongoing evaluation that demonstrates achievement of these objectives and uses the results to improve the effectiveness of the programme: Ongoing evaluation is carried out for both the US (*Middle States*) and UK (*The Open University – CICP*) institutional reviews, and independently by departmental members (when updating modules) and by students (during regular faculty-student meetings). The LTPC closely analyses the APEs of all degree programmes, and The University's response to the AMR is considered at the Schools and at LTPC. An additional formal and substantive review takes place every five years during the revalidation process of Richmond's degree programmes by The OU.

2.4. External contexts:

B.A. (Hons) Social Sciences: Psychology with Combined Studies is provided through a system of ongoing evaluations that demonstrate achievement of the programme's objectives, and uses the results to improve the effectiveness of the programme. Ongoing evaluation is carried out for both the US (Middle States) and UK (The Open University – CICP) reviews. Richmond is a voluntary subscriber member of the QAA, and underwent its first full Institutional Review in May 2013 (<http://www.richmond.ac.uk/content/admissions/about-richmond/american-british-accreditation.aspx>).

Students are encouraged to attend meetings, lectures at other London universities, institutions, and join the BPS as is appropriate.

Students are eligible for the graduate basis of registration with the British Psychological Society, provided that their GPA is 3.0 or above; and if half of their overall credits are psychology, psychology-related or required courses. Students wishing to remain in the UK to work or continue on to postgraduate studies are encouraged to apply for membership of the British Psychological Society.

The Psychology team continue to meet BPS standards without losing our Liberal Arts ethos and identity. This is not always an easy balance to strike and it requires continuous update of the curriculum. The team feel that we accommodate the demands of the BPS in terms of the requirements for accredited courses. The BPS requires for accredited courses to cover a variety of content. While the exact content of psychology degree courses may vary from university to university, all courses accredited by the Society include:

- **Biological psychology** - how the brain influences behaviour, the effects of hormones, how it can be affected by drugs.
- **Cognitive psychology** - how we remember, learn, think, reason, perceive, speak and understand.
- **Developmental psychology** - how humans develop physically, mentally and socially during childhood and adolescence and their life span.
- **Social psychology** - how human behaviour and experience are affected by social context such as in groups and relationships.
- **Conceptual and historical issues** - how psychological explanations have changed over time and key debates, which shape its future.
- **Research methods** - quantitative and qualitative methods, research design, data collection, analysis and interpretation.

Furthermore, it is assumed by the BPS that degrees can allow students to select their own courses in addition to core content and require some form of independent project and practical work. (<http://www.bps.org.uk/careers-education-training/undergraduate-and-postgraduate-psychology/undergraduate-and-postgraduate->).

All of the above courses feature in the Richmond Psychology Programme and conform to the course descriptions provided by BPS.

3. Programme Outcomes

Programme-level learning outcomes are identified below. The Psychology degree at Richmond, the American International University in London is a four year programme where the discipline is studied along side a range of other subjects. Progression through the Psychology degree is set out down each of the four columns of the Programme Outcome grid – with level-specific programme outcomes at the 3000, 4000, 5000 and 6000 level. The programme outcomes are then applied in each module of the Psychology degree through assessed, courses-specific learning outcomes. The four broad categories of Programme Outcomes are:

- A) Theoretical Knowledge Base
- B) Practical Knowledge Base
- C) Cognitive Skills
- D) Personal Development

Please refer to Appendix I – Curriculum Map for details of how outcomes are deployed across the study programme.

3.1. Theoretical Knowledge Base ('A')

LEVEL 3

- i. an basic understanding of the core areas in psychology such as developmental, social and biological psychology, theories in those areas, how they interact, and inform disciplines such as neuroscience, law, marketing and sociology

LEVEL 4

- i. a broad understanding of the links between domains of knowledge in psychology
- ii. a broad understanding of how issues in modern psychology relate to historical intellectual problems and provide a framework for current debates
- iii. a broad understanding of the major areas in developmental and biological psychology and the scientific methods that gave rise and continue to shape theories in those areas

LEVEL 5

- i. a detailed awareness of the ways in which to engage critically with major thinkers, debates and intellectual paradigms within the subject area and put them to productive use
- ii. a detailed awareness of the connections between the theories and their applications in experimentation and to be able to critically evaluate these
- iii. an detailed understanding of the ways experimental methods are contextualised and contribute to the formulation of interpretations of research findings in psychology

LEVEL 6

- i. a systematic understanding of the historical evolution of theories and systems in psychology, their influence on current debates and their limitations
- ii. a systematic understanding of the variety of influences on psychological functioning and how different approaches conceptualise these, leading to an ability to critically evaluate schools of thought

- iii. a systematic understanding of several specialised areas and applications such as developmental psychopathology, cognitive science and counselling theory
- iv. a systematic understanding of a range of research paradigms, qualitative and quantitative methods, and being aware of their limitations

3.2. Practical Knowledge Base ('B')

LEVEL 3

- i. a basic insight into the scientific methods that gave rise and continue to shape psychological theory

LEVEL 4

- i. a broad understanding of the ways in which different quantitative and qualitative methodologies are used best when specific phenomena are examined
- ii. a broad insight into the ethical decisions made by psychologists and implications of these within the psychological context
- iii. a broad understanding of quantitative and qualitative statistical analysis and software currently used by researchers in psychology

LEVEL 5

- i. a detailed understanding of how to produce an empirical study proposal and report which develops their argument and integrates a theoretical framework and research methodology with their analysis
- ii. a detailed understanding of carrying out empirical studies using a variety of methods within ethical and laboratory constraints
- iii. a detailed understanding of the use of APA standards in the presentation and evaluation of research findings

LEVEL 6

- i. a systematic understanding of ways to integrate ideas and findings across multiple perspectives and recognising different approaches to practice
- ii. a systematic understanding of scientific reasoning, the role of evidence and how to make critical judgements of arguments in psychology
- iii. a systematic understanding of and engagement with ethical principles and approval procedures relating to research projects, and being aware of the ethical context in psychology as a practitioner or researcher
- iv. a competence in initiating, designing, conducting and reporting empirical research using qualitative and quantitative methods, under minimal supervision, and recognise the theoretical/practical applications and limitations of those projects

3.3. Cognitive Skills ('C')

LEVEL 3

- i. demonstrates the ability to gather, organise and deploy ideas and information in order to communicate arguments effectively in written, oral or other forms, with an understanding of appropriate methods

LEVEL 4

- i. demonstrates the ability to gather, organise and deploy ideas and information in order to evaluate their strengths and weaknesses, and express them effectively in written, oral or other forms
- ii. demonstrates a broad understanding of quantitative and/or qualitative research methods

- iii. demonstrates an ability to judge the reliability of sources, and begins to identify the strengths and weaknesses of concepts and theoretical frameworks

LEVEL 5

- i. demonstrates the ability to formulate and synthesize arguments cogently, retrieve and generate information, and select appropriate criteria to evaluate sources, with a detailed understanding of quantitative and/or qualitative methods
- ii. delivers work with limited supervision to a given length, format, brief and deadline, properly referencing sources and ideas and making use, as appropriate, of a problem-solving approach
- iii. exercises a degree of independent and informed critical judgement in analysis

LEVEL 6

- i. demonstrates the ability to gather, organise and deploy complex and abstract ideas and information in order to formulate arguments cogently, and express them effectively in written, oral or other forms
- ii. demonstrates the ability to organise and manage supervised, self-directed projects, through which a sophisticated understanding of research methods is demonstrated
- iii. demonstrates the ability to produce detailed analyses of competing perspectives and concepts, to make comparisons and connections and to identify the possibility of new concepts
- iv. demonstrates the ability to provide critically appraisals of some of the widespread common sense understandings and misunderstandings of the subject area, and the debates and disagreements to which these give rise

3.4. Personal Development

LEVEL 3

- i. demonstrates an awareness of views other than their own and adapts behaviour to meet obligations in personal and/or group outcomes and/or outputs

LEVEL 4

- i. acts with limited autonomy under direction or supervision and engages in evaluation of own work and capabilities and outputs in key areas
- ii. demonstrates the ability to work productively in a group or team, recognising the factors that affect team performance
- iii. demonstrates the ability to use a range of information communication technology (ICT) skills to perform tasks

LEVEL 5

- i. demonstrates the ability to engage in self-reflection, and uses feedback to adapt own actions and interpersonal communication skills to a range of contexts, audiences and degrees of complexity
- ii. delivers work with limited direction or supervision, demonstrating the capacity to consider and evaluate their own work using justifiable criteria.
- iii. demonstrates the ability to adapt to complex and non-routine performance tasks using information communication technology (ICT)

LEVEL 6

- i. demonstrates the ability to act with minimal direction or supervision, to engage in self-reflection, use feedback to analyse own capabilities, appraise alternatives, and plan and implement actions
- ii. demonstrates personal responsibility and professional codes of conduct, while taking responsibility for their own work, learning and development, and effectiveness in professional and interpersonal communication

- iii. demonstrates the ability to work effectively within a group or team, including skills such as listening, contributing, leading, negotiating and proactively managing conflict as is appropriate
- iv. demonstrates the ability to flexibly locate their own normative views and cultural commitments within the practice of research, with a level of autonomy

4. Teaching, learning and assessment strategies

4.1. Teaching and learning strategies

The teaching and learning strategy adopted within *B.A. (Hons) Social Sciences: Psychology with Combined Studies* is summarised below:

- Teaching is through lectures, seminars, tutorials, and workshops
- Use of in class experimental demonstrations, practical projects, case analyses
- Courses in subject area followed by relevant practical or laboratory classes
- Use of audio-visual aids and a variety of multi-media sources
- Regular use of individual and /or team based projects
- Regular use of individual and/or group presentations
- Regular use of self-directed and directed reading in all courses
- Use of Library resources, digital resources and online catalogues, newspaper reports on Psychology related issues
- Use of occasional guest lecturers from specialist areas
- Student participation in internal and external Psychology Conferences
- Frequent feedback on coursework and through one to one meetings with faculty and small group discussions
- Frequent guidance on degree path
- Regular use of tutor and student led discussions groups via e-learning platforms such as PowerCAMPUS in many courses

The combination of teaching and learning approaches mentioned above develops our students' knowledge, thinking skills and practical skills.

Their knowledge is acquired through

- Structured lectures and supporting materials
- Directed reading and use of internet materials
- Independent research

Their thinking skills are developed through

- Conducting research, constructing arguments
- Statistical analyses
- Making presentations and preparing other assessments
- Helping others to learn
- Project work employing a problem solving methodology

Their practical skills are gained through

- Application of theory to practice, especially during lab and experimental work and internships
- Using information technology to retrieve and manipulate data
- Negotiating with others in group projects

4.2. Assessment strategy

Assessment is conducted using various methods: essays, commentaries, oral presentations, research proposals, research papers, poster presentations, independent research projects, group experimental studies and examinations which focus on the critical evaluation of material and the application of theory.

Standard Assessment Norms			
FHEQ level	Richmond/UK Level	Normal number of items (including final exam)*	Total assessment
Level 3	R3000/UK A-Level	3-4	1 two-hour final exam plus 2000-2500 words
Level 4	R4000/UK Year 1	3-4	1 two-hour final exam plus 2000-3000 words
Level 5	R5000/UK Year 2	2-3	1 two-hour final exam plus 3000-4000 words
Level 6	R6000/UK Year 3	2-3	1 two-hour final exam plus 3000-4000 words
Level 7	R7000/UK MA	2-3	5000-7000 words

*** Reasonable adjustments should be made for assessment activities such as midterm exams, in- class presentations, group assignments, tests etc. Any summative assessment activities must be reflected in the final overall assessment count.**

Excluding all atypical courses, the following should apply to all courses:

- All undergraduate courses should include one 2-hour final exam, with exceptions approved by the department.
- Final exams should normally be no less than 25% and no more than 50% of the overall final grade.

- Instructors may not fail a student solely for failing the final exam if all graded activities result in a passing grade for the course.
- Midterm exams are not obligatory.
- At Level 3, the normal length per item should be between 500-1000 words, or equivalent (not including finals).
- At Level 4, the normal length per item should be between 1000-1500 words, or equivalent (not including finals).
- At Level 7, word count will need to take into account the inclusion of a final exam.
- Attendance and participation cannot be assessment activities.
- Formative assessments are at the discretion of the instructor and do not count toward the number of items or toward the total word count.

Writing Intensive Assessment Norms			
FHEQ level	Richmond/UK Level	Normal number of items	Total assessment
Level 3	R3000/UK A-Level	3-4	3000-3250 words
Level 4	R4000/UK Year 1	3-4	3000-4500 words
Level 5	R5000/UK Year 2	2-3	4500-6000 words
Level 6	R6000/UK Year 3	2-3	4500-6000 words

Courses designated as Writing Intensive differ from the Standard Assessment Norms by:

- No final exam
- The total amount of written words will normally increase by 50%

There are some other exceptions and those courses will follow a Special Programmes (eg. ADM, ARW) or Dissertation table approved on 28 June 2012 by Academic Council. Details of these can be found at: <http://www.richmond.ac.uk/content/academic-affairs/academic-standing.aspx>

For courses that have atypical assessment norms and do not follow one of the approved tables, assessment will first be approved by Learning and Teaching Policy Committee.

Grade Assessment Criteria/Marking Scheme

In order to obtain a *B.A. (Hons) Social Sciences: Psychology with Combined Studies* students require (amongst other requirements) a cumulative GPA across the entire degree of 2.0. This is a 'C' average. A minimum GPA of 2.0 must also be achieved in all courses taken to fulfil major requirements. For information on the calculation of the OU GPA as a basis for final degree classifications, see the myacademics page of the university portal at: <https://my.richmond.ac.uk/myacademics/default.aspx>

Course syllabi documents clarify, for each learning outcome, how that particular learning outcome is assessed, and what the threshold criteria for that particular learning outcome is, specified at the 'C' (GPA 2.0) level (i.e. a passing grade)

There are three 'pass' grades (and 7 sub-categories of 'pass' grade) in the *B.A. (Hons) Social Sciences: Psychology with Combined Studies*. The following general criteria are used to distinguish between these grades:

Grade A applies only to the exceptional piece of work which:

- has continued beyond the B grade band to develop a more advanced analytical and integrative command of the material and issues
- gives evidence of very wide reading and extensive knowledge of relevant theory and recent research
- is very well structured, putting forward cogent arguments which are well supported by carefully evaluated evidence
- superior (A-) or outstanding (A)

Grade B applies to work which:

- goes beyond the foundation level to develop a more questioning and analytical approach
- goes beyond the basic required reading, to study and discusses recommended texts and articles
- indicates an increasing ability to appreciate an extensive body of knowledge and to conceptualize the key theories, issues, debates and criticisms
- demonstrates the skills to present a balanced and comprehensive discussion
- has been completed with a thoroughness aimed to get the most learning out of the exercise
- good quality (B-), very good (B), or excellent (B+)

Grade C applies to work which:

- is basically competent, although undeveloped
- fulfils the requirements of the assignment at a foundation level, involving:
 - adequate coverage of the essential information specified, and
 - the skill to present that material coherently
- selects relevant named references and quotations
- just below average (C-), average (C), or showing signs of reaching above average (C+)

Grade D applies to work which:

- has been done without proper understanding of the requirements
- is too short, or long and unedited or lacks structure
- relies on superficial, subjective statements
- uses unreliable and inappropriate sources, **such as Wikipedia**
- uses incorrect, or confused information
- fails to make proper use of named references and quotations
- unsatisfactory work (D-), very poor work (D) and work which is weak (D+)

Grade F, a fail, applies to:

- non-submission of work or work which is illegible
- late work after one extension has been given
- work which may be competent, but is either:
 - irrelevant (i.e. does not address the requirements of the assignment), or
 - uses un-attributed material (plagiarism)

5. Programme structure:

5.1. B.A. (Hons) Social Sciences: Psychology with Combined Studies

A normal courseload per academic year is 30 US credits, equivalent to 120 UK credits. Students complete 120 UK credits at Level 6 in the major.

Please see degree chart below and refer to Appendix 2: Programme Structure Flowchart.

Table 1: Lower-Division/Levels 3 and 4 degree requirements

		US Credits	UK Credits
LOWER-DIVISION REQUIREMENTS (Total)		62	248
FHEQ Level 3 (Total)		31	124
PSY 3100	Foundations in Psychology	3	12
PSY 3105	Foundations in Social Psychology	3	12
	<i>5 further courses (core curriculum requirements)</i>	16	64
	<i>3 further courses (mathematical or Academic Literacy requirements, or electives for students with exemptions)</i>	9	36
FHEQ Level 4 (Total)		31	124
MTH 4120	Probability and Statistics 1	3	12
PSY 4200	Beginning Human Science Research	3	12
PSY 4205	Conceptual and Historical Issues in Psychology	3	12
PSY 4210	Developmental Psychology	3	12
PSY 4215	Biological Basis of Human Behavior	3	12
	<i>3 further courses (core curriculum requirement)</i>	9	36
	<i>2 further courses (Academic Literacy requirement and/or electives)</i>	7	28

Table 2: Upper-Division/Levels 5 and 6 degree requirements

		US Credits	UK Credits
UPPER DIVISION MAJOR REQUIREMENTS		64	256
FHEQ Level 5 (Total)		32	128
PSY 5100	Human Development	3	12
PSY 5200	Theories of Personality	3	12
PSY 5205	Quantitative Methods in Psychology	4	16
PSY 5210	Experimental Methods in Psychology	4	16
plus two of the following:		6	24
PSY 5400	Mind and Language		

PSY 5405	Psychopathology		
PSY 5410	Human Sexuality		
PSY 5415	Psychology and Cinema		
PSY 5420	Arts Psychotherapies		
MGT 5400	Organisational Behaviour		
	<i>1 further course (core curriculum requirement)</i>	3	12
	<i>3 further courses (electives)</i>	9	36
FHEQ Level 6 (Total)		32	128
PSY 6200	Theories and Systems in Psychology	3	12
PSY 6205	Developmental Psychopathology	3	12
PSY 6210	Cognitive Science	3	12
PSY 6391	Senior Project in Psychology I: Quantitative Methods	4	16
PSY 6392	Senior Project in Psychology II: Qualitative Methods	4	16
plus five of the following OR Internship and three of the following		15	60
PSY 6400	Psychoanalysis		
PSY 6405	Existential-Phenomenological Psychology		
PSY 6410	Memory and Awareness		
PSY 6415	Counselling Theory and Practice I (4 CREDITS)		
PSY 6420	Counselling Theory and Practice II (4 CREDITS)		
PSY 6962	World Internship in Psychology (6 CREDITS)		
PSY 6972	Internship in Psychology (6 CREDITS)		

5.2. Minor requirements

Students may select Psychology as an optional minor to complement their major field. Both the major and minor will be recorded on the student's transcript at graduation. At least three of the upper division courses required for a minor must be taken at Richmond. A maximum of three courses only may overlap between a student's major and any minor.

		US Credits	UK Credits
Minor Requirements		18	72
PSY 3100	Foundations in Psychology	3	12
plus one of the following		3	12
PSY 3105	Foundations in Social Psychology		
PSY 4210	Developmental Psychology		
plus four additional psychology courses, at least three at 5000-level or higher		12	48

6. Regulatory framework

B.A. (Hons) Social Sciences: Psychology with Combined Studies is operated under the policy and regulatory frameworks of Richmond the American International University in London, the Middle States Commission on Higher Education, the *Framework of Higher Education Qualifications*, *UK Quality Code for Higher Education*, and The Open University policies and procedures for validated institutions.

The following sub-sections include the relevant University or institutional policy documents, where applicable.

6.1. Admissions

To be considered for admission, prospective students should:

- normally be at least 17 years old, have completed a minimum of 12 years of schooling, and hold the required grade(s) in a complete US high School Diploma, UK GCE A levels, or other UK or international qualifications deemed equivalent by the University, by the start of the programme;
- have completed an application via UCAS, the Common Application or direct to the University, including a personal statement and academic reference and supplying verification of existing academic and English language attainments as required by the University.

Further details of qualifications accepted and grades required may be found on the University website, noting that these are common to all BA programmes at the University and there is no requirement as to the subject of entry qualifications. Prospective students from the United States should note that SATs are optional but not required. Whilst not routinely required, prospective students may be invited to interview where this is considered necessary in order to fully consider their application.

Prospective students with specific levels of subject achievement in Advanced Placement Tests, GCE A Levels and some other UK and international qualifications may enter with Advanced Credit and be given exemption from certain courses of the programme. Normally, Advanced Credit may be given for a maximum of 30 out of the total 120 (US) credits necessary to complete the programme. The University welcomes also applications from prospective students with previous Higher Education study who, depending on subjects taken and grades achieved, may be given up to 75 Transfer Credits against the total 120 (US) credits necessary to complete the programme.

Students who are not nationals of a majority English-speaking country should normally have achieved CEFR level B2 in a secure English Language test acceptable to the University prior to entry to the programme. At the University's discretion, students in this category who are EEA nationals may be excused this requirement where they have recently undertaken a full time programme of study of at least 2 years duration with English as the medium of instruction.

Prospective students who do not meet the above academic and/or English language requirements may be permitted to enter this programme at the appropriate point after having first satisfactorily completed a Foundation Year and /or Academic English language programme at the University.

Further details of all of the above may be found at the appropriate page of the University website, where a comprehensive Admissions Policy and Summary of Practice document is also published: <http://www.richmond.ac.uk/content/admissions.aspx>

6.2. Assessment

A proper assessment of student learning and progression of skills gained is fundamental to the work of the University. Much of what shapes the University's perspective on this has already been mentioned within section 4.2, above, under Assessment Strategy, which has been shaped in accordance with the expectations outlined in Section B6 of the *UK Quality Code for Higher Education*.

The University is also in compliance with Standard 14 on 'Assessment of Student Learning', as laid out by the Middle States Commission on Higher Education. Standard 14 includes the following passages:

"The systematic assessment of student learning is essential to monitoring quality and providing the information that leads to improvement. Implemented effectively, the assessment of student learning will involve the shared commitments of students, administrators and academic professionals... Assessment is not an event but a process and should be an integral part of the life of the institution."

(<http://www.msche.org/publications.asp>).

6.3. Progression

Progression is built into the Programme Outcomes (Section 3 above), as they are derived from the *SEEC* categories associated with specific levels of the *FHEQ*. Learning outcomes in each individual course are therefore level-specific, ensuring an appropriate structure of progression through the degree, with students at graduation meeting the requirements of the QAA subject benchmarks.

6.4. Placement

The Internship Office the University offers a formal mechanism through which students may receive work-placement opportunities. These placements are supervised, career-related work experiences combined with reflective, academic study that help students apply theoretical knowledge in the workplace. Participation in the internship programme is optional, but students who choose to take up a placement receive academic credit for their placement and associated academic work. For full details of the internship programme, please see: <http://www.richmond.ac.uk/content/academic-programs/internships.aspx>

Expectations with regard to careers education, information, advice and guidance (as outlined in Section B4 of *The UK Quality Code for Higher Education*) are handled by the university's Student Affairs department. This department conducts a variety of career services for students, ranging from resource provision to a CV service, and in particular through the LEAD (Leadership, Education and Development) seminar series. For full details of career services offered to students at Richmond, please see: <http://www.richmond.ac.uk/content/student-affairs/career-services.aspx>.

In addition to these services, the alumni office offers networking opportunities where students may contact alumni working in a variety of fields. The alumni office also offers these services via social media such as LinkedIn and Facebook. Please see: <http://www.richmond.ac.uk/content/alumni.aspx>

6.5. Study abroad

Richmond classes benefit every semester through the arrival of c. 100 study abroad students from colleges and universities within the United States. These students, who mostly enrol in classes at levels 5 and 6, very often bring with them a distinct set of values and approaches to learning that can be both enriching and challenging. Richmond faculty have the breadth of experience necessary with which to capitalise on the positive aspects of this class room dynamic. Please note that Study Abroad students register for classes *after* Richmond degree-course students have completed their registration process.

Richmond students have the option to take a leave of absence and travel away from the university as a 'study abroad'. In practice, however, very few students take this option up. It is more common for Richmond students to take a limited number of classes at other accredited colleges and universities during the summer, and then transfer these back to Richmond for inclusion toward their graduation requirements. All courses taken elsewhere must be pre-approved by the Office of Academic Affairs. All such courses are rigorously scrutinized, and only credit from appropriately accredited programmes, earned with a grade of C or above, are accepted for transfer. There are strict requirements regarding the number of courses and at what level may be taken outside of Richmond. Please see under "Graduation Requirements" at:

<http://www.richmond.ac.uk/content/academic-affairs/graduation/graduation-requirements.aspx>

6.6. Student support and guidance

All students have an allocated full-time faculty member who acts as their academic adviser. Academic Advisers have on-going responsibility for students' academic progress, meeting with each advisee at least once per semester. Advisers assist students with registration, enabling smooth progression through the degree. They also advise on postgraduate and career opportunities, and also provide pastoral support in many cases.

A range of Maths, English, Technology and Writing workshops have been established to support students with particular needs in these areas. Librarians are on hand to assist with library use, which includes instruction in web-based resources.

In accordance with the 2010 *Equality Act*, and with Chapter B4 of the *Quality Code for Higher Education* (Section 2: Disabled Students) Richmond endeavours to make all practical and reasonable adjustments to ensure students are able to fully participate in the University community. Students who declare a physical disability or a special educational need are accommodated to ensure the quality of their educational experience meets their individual requirements. SEN students, for instance, receive extra time in examinations, and have the option of writing exams on university-provided computers, and/or of taking exams in a separate room. Please see:

<http://www.richmond.ac.uk/content/student-affairs/students-with-disabilities.aspx>

The university operates a well-staffed Student Affairs department that provides services intended to support and encourage student welfare, safety and development. This department oversees medical registration of students and provides counseling services. It also organizes a range of extracurricular activities and travel designed to further enhance students' educational experiences. Disciplinary and social grievance procedures are also overseen by this department. For a full description of Student Affairs' activities, please see: <http://www.richmond.ac.uk/content/student-affairs.aspx>

Student feedback on the programme is given in a set of complimentary ways:

1. Through the regular advising sessions that faculty members hold with students (particularly their academic advisees). Each student at Richmond University is assigned an academic advisor, generally from their area of major. Psychology students are therefore normally assigned a full-time member of the Psychology teaching team as their academic advisor. During their first year of study, these students might be assigned an advisor from another department as part of their First Year Experience. This endeavors to create a close relationship between student and advisor, here on the basis of a chosen first year seminar. The advising sessions have had the purpose of assisting students in their choice of courses to guarantee a correct study path. The sessions are also vital in providing students with the opportunity to share experiences and information with teaching staff.
2. Through formal teaching evaluations for each course in the programme. At the end of each semester students are required to fill in teaching evaluation forms for each course they have studied. The forms are standardized and ask the students to rank the course and the lecturer according to content, teaching style and delivery. The forms are centrally collated and the results are returned to the faculty member once final grades have been submitted. The faculty member also has the opportunity to read the comments provided anonymously by students. A section of class time is specifically allocated to this process – a responsible student is designated to collect the evaluations and submit them to the Provost's Office for analysis. These forms are comprised of both qualitative and quantitative elements
3. Through a bi-annual meeting with Psychology students. This meeting consists of a discussion on the strengths and limitations of the programme. It provides a forum for students to express any concerns they had during the academic year and to confirm if improvements in the programme have been successful. The comments arising from these meetings are viewed as representative of the Psychology majors as a whole, and are consistent with informal feedback mechanisms. The feedback for the programme is discussed by Psychology faculty both informally and at Department meeting. The information that is collected through the above ways is discussed with the Chair of the Department and items which require action are followed up.

Appendix 1 - Curriculum map

This table indicates which study units assume responsibility for delivering and assessing particular programme learning outcomes.

LEVEL 3	PSY 3100	PSY 3105			
3A(i)	X	X			
3B(i)	X	X			
3C(i)	X	X			
3D(i)	X	X			
LEVEL 4	MTH 4120	PSY 4200	PSY 4205	PSY 4210	PSY 4215
4A(i)		X	X	X	X
4A(ii)			X		
4A(iii)				X	X
4B(i)	X	X			
4B(ii)		X	X	X	
4B(iii)	X	X			
4C(i)			X	X	X
4C(ii)	X	X			
4C(iii)			X		X
4D(i)		X	X		
4D(ii)		X			X
4D(iii)			X	X	X

LEVEL 5	PSY 5100	PSY 5200	PSY 5205	PSY 5210	PSY 5400	PSY 5405	PSY 5410	PSY 5415	PSY 5420
5A(i)	X	X			X	X	X	X	X
5A(ii)		X		X					X
5A(iii)				X					
5B(i)		X	X	X					
5B(ii)			X	X					
5B(iii)			X	X					
5C(i)	X	X	X	X	X	X	X		X
5C(ii)		X						X	
5C(iii)	X							X	
5D(i)	X	X		X	X	X	X		X
5D(ii)				X	X		X	X	
5D(iii)			X	X					

LEVEL 6	PSY 6200	PSY 6205	PSY 6210	PSY 6391	PSY 6392	PSY 6400	PSY 6405	PSY 6410	PSY 6415	PSY 6420
6A(i)	X					X			X	X
6A(ii)	X							X		
6A(iii)		X	X			X	X			
6A(iv)				X	X					
6B(i)		X	X			X			X	X
6B(ii)	X		X					X		
6B(iii)				X	X				X	X
6B(iv)				X	X					
6C(i)	X	X	X	X		X		X	X	X
6C(ii)				X	X					
6C(iii)	X		X				X	X		
6C(iv)	X	X	X			X	X	X		
6D(i)		X		X	X				X	X
6D(ii)				X	X				X	X
6D(iii)	X		X			X		X	X	X
6D(iv)				X	X		X			

Appendix 2 - Programme structure

Typical Degree Schema: B.A. (Hons) Social Sciences: Psychology with Combined Studies. *(Note: Based on a Freshman entering Richmond with no Transfer Credit and opting for one or two Minor subjects.)*

YEAR ONE:

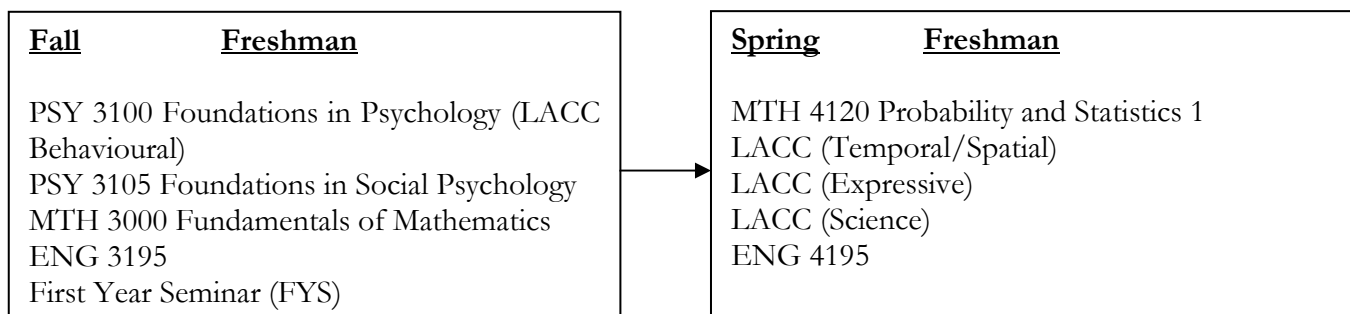

YEAR TWO:

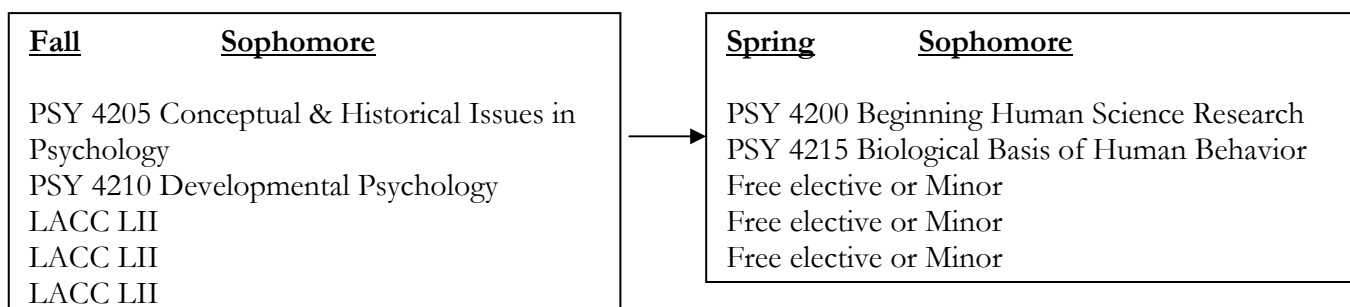

YEAR THREE:

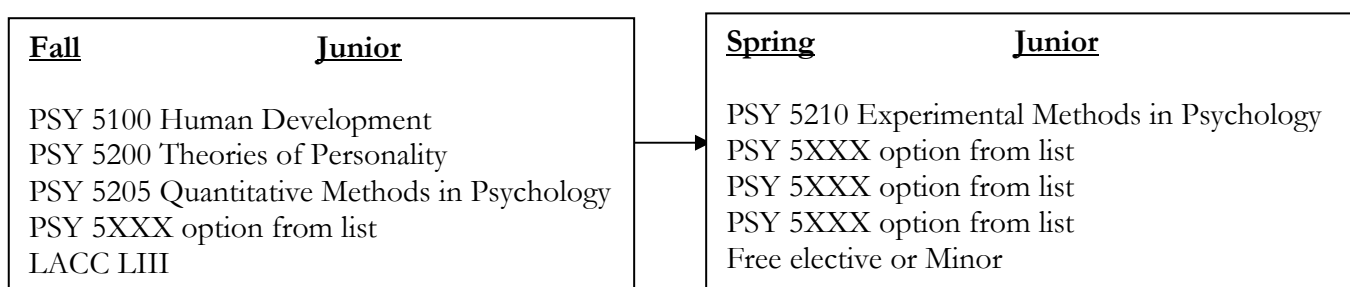

YEAR FOUR:

